

EN	DE
Product Information	Produktinformationen
according to DIN 6650, DIN 3542 and FDA regulations	Produkt nach DIN 6650, DIN 3542 und FDA Bestimmungen
gastight	gasdicht
for specific length calculation keg drawing or H3-dimension is needed according to DIN 6647	Für konkrete Längenberechnung wird die Keg-Zeichnung oder das H3-Maß nach DIN 6647 benötigt
mounting torque -	Anzugsdrehmoment: -
temperature resistance short-time 160°C	Temperaturbeständigkeit kurzfristig 160°C
for more information www.dispensegroup.com	für mehr Informationen www.dispensegroup.com

EN	DE		
Stroke and Passages	Hub und Öffnungsquerschnitte		
I main seal part 7 - part 8	Dichtung Pos. 7 - Pos. 8	A	9-12 mm
II trough inner tube ϕ 17,6 mm part 1	innerhalb des Steigrohres ϕ 17,6 mm Pos. 1	B	240 mm ²
6 holes in part 1	6 Löcher in Pos. 1	C	100 mm ²
III through outer tube part 8 - part 7	außerhalb des Steigrohres Pos. 8 - Pos. 7	D	400 mm ²
in part 7	in Pos. 7	E	800 mm ²

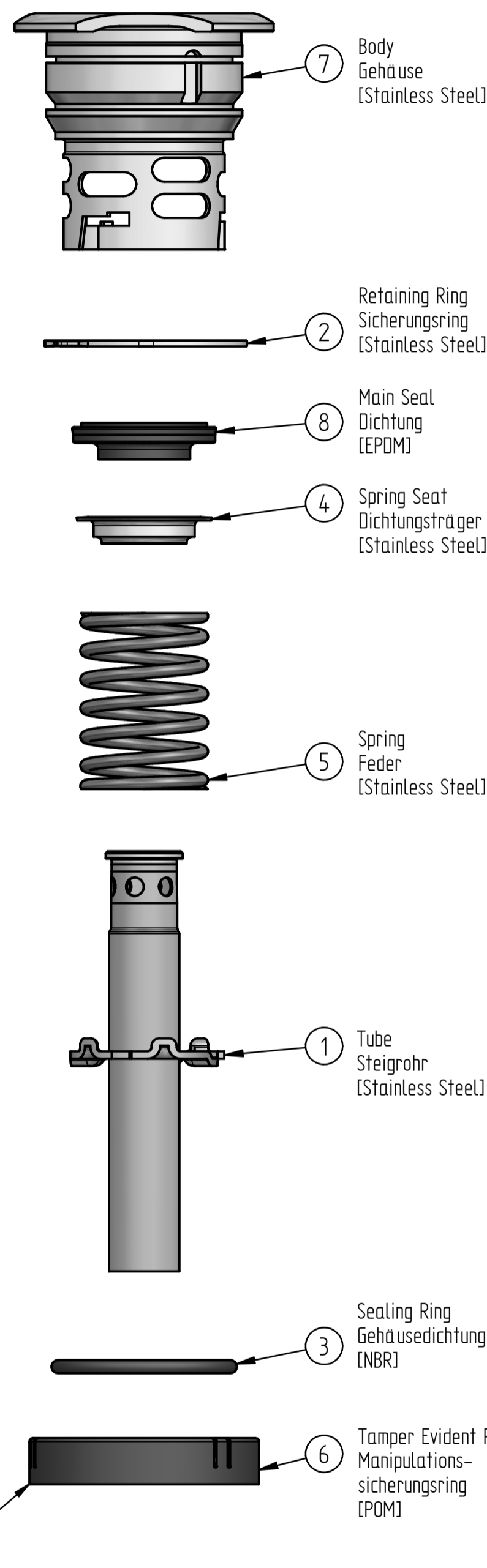
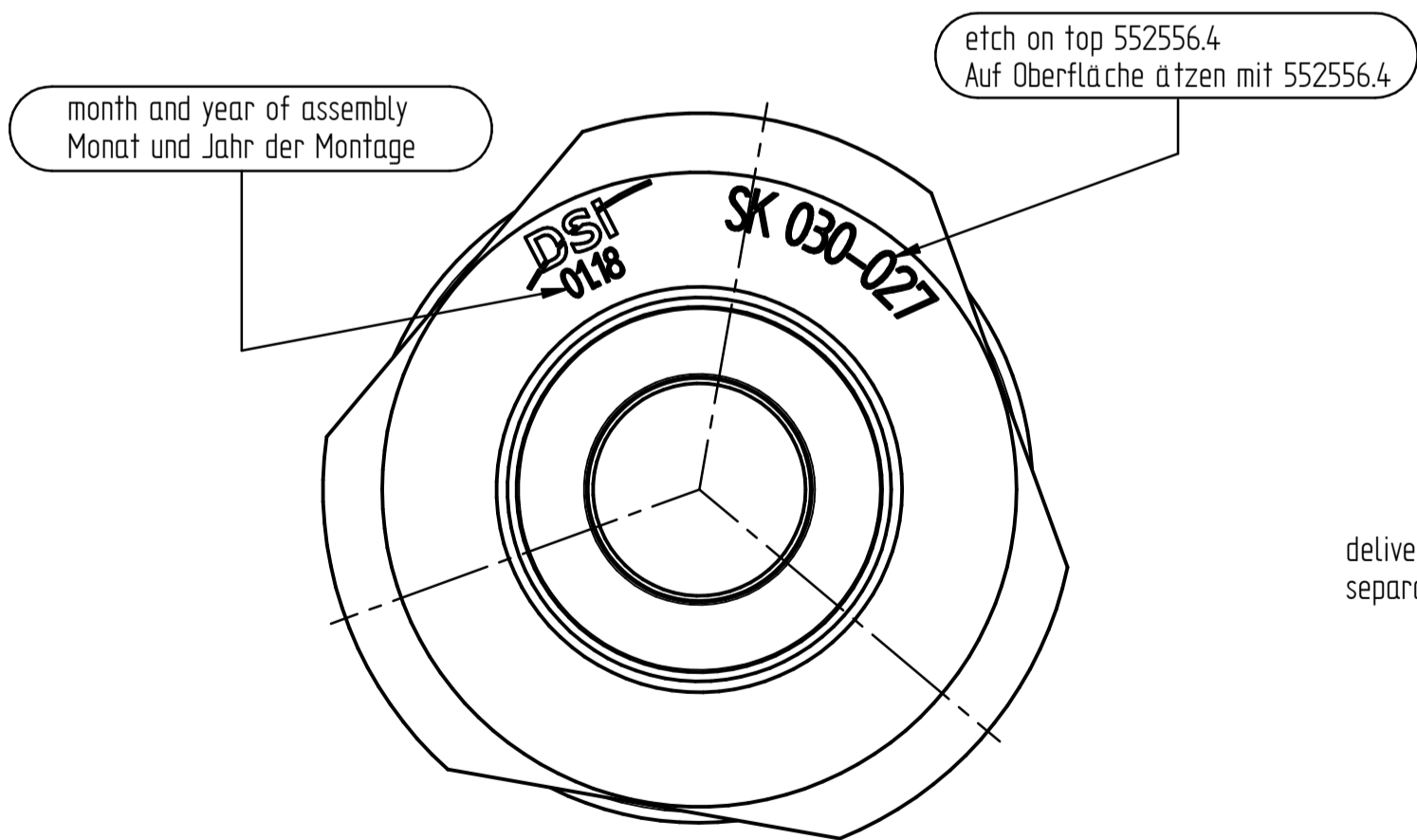
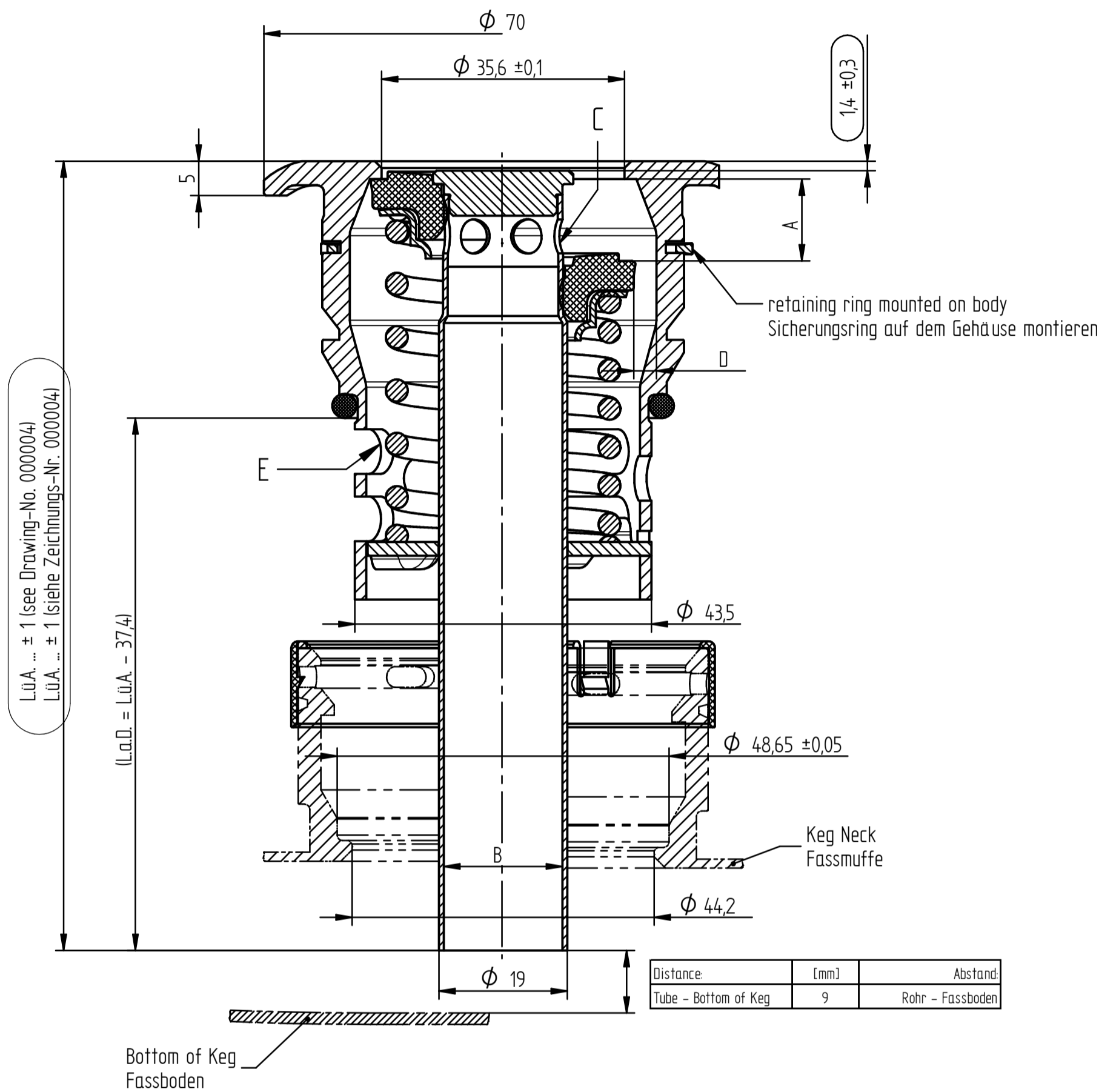

weight calculation \pm 5% / Gewichtsrechnung \pm 5%

$$m [g] = (L. \ddot{u}. A. [mm] - 25mm) * 0,315 \frac{g}{mm} + 350g$$

Pos.	Quantity	Art.-No.	Title
1	1	000002	Master Down Tube Assembly (loose Safety)
2	1	026418.7	Retaining Ring
3	1	026708.0	O-Ring 40,87 x 3,53
4	1	551082.4	Spring Seat
5	1	551083.5	Spring
6	1	552623.5	Tamper Evident Ring, black
7	1	610006	Body machined GRB
8	1	610116	Main Seal 160°C saturated steam

PRODUCT		TOLERANCES DIN ISO 2768-mS	LAST CHANGE	SCALE 1,5:1 (11,25)	WEIGHT VOLUME
		ROUGHNESS DIN EN ISO 1302	- X Δ	MATERIAL	
		EDGES DIN EN ISO 13715		TITLE	
DESIGN	DATE	NAME	Master Extractor Tube GR B		
AM	21.09.2018	kunze			
4125					
DATE	24.09.2018	kunze			
FILE NAME	000143_Masterdrawing ET GR B.dwg				
DRAWING NAME	000143_Masterdrawing ET GR B.dwg				
PROJ. METHOD	FORMAT	DRAWING NUMBER	SHEET		
DSI	A2	000143	1		
MICRO MATIC			1		
ALTERATIONS	DATE	NAME	AM	PROD. DEV.	GERMANY
				REPL.	

DSI Getränkeautomaten GmbH.
 This drawing is the property of Dispense Systems International.
 The information is confidential and should not be copied for
 any other purpose without the prior written permission of
 Samples are required after each revision.